



MURPHY®

by **ENOVATION** CONTROLS

POWERCORE® TEC-10

SUPERIOR TURNKEY PANEL OFFERS COMPLETE CONTROL, FAMILIARITY ACROSS APPLICATIONS



- Supports SAE J1939 CAN protocols
- Change settings from the face of the panel
- Rugged panel withstands dust, water and vibration
- Can be utilized across many applications providing familiarity for users



Murphy's PowerCore® TEC-10 panel provides full control of your engine including auto start/stop, auto throttling and display of engine parameters along with critical faults from the engine/application. The TEC-10 supports SAE J1939 CAN protocols for electronically governed engines as well as analog sensors on mechanical engines for fault and safety warnings/shutdowns.

An incredibly versatile control panel, the TEC-10 allows parameters and settings to be changed directly from the front face or via a free PC configuration tool. Powerful flexibility allows for the same control panel to be used across a wide range of applications while providing operator consistency and familiarity.

The control panel features molded-in industry-standard connectors mating with Deutsch HDP series connectors and

is compatible for use on the simplest mechanical engine to the most advanced, fully electronic Tier 4 engines.*

Designed as a plug-and-play solution, the TEC-10 panel is perfect for rental or industrial applications where I/O is needed and auto start or auto throttling is desired.

The rugged TEC-10 panel can be mounted directly to the engine or engine/application cover. Built to endure industrial environments from full sun to wide temperature ranges, the panel features a high degree of sealing for dust and water as well as the ability to withstand higher vibration with exposure.

*Murphy Industrial Harness or John Deere OEM engine harnessing required.

Standard Dimensions

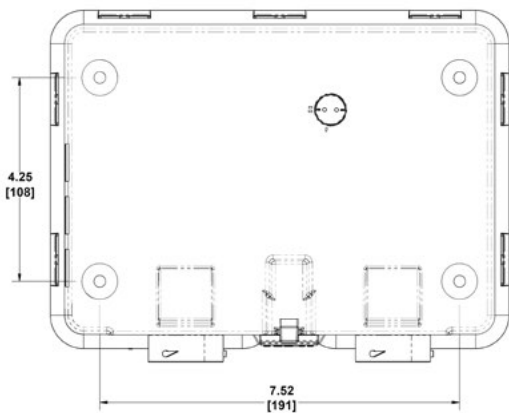
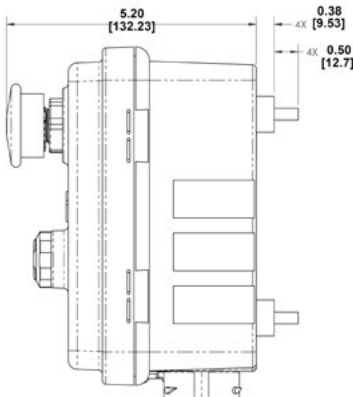
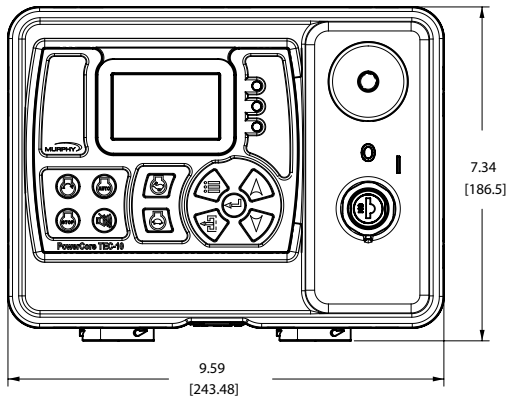

• **Interface**

Display:

- Monochrome HR-TFT
- 2.7 in./ 68 mm, WQVGA (400 x 240 pixels)
- Languages: English, Spanish, German, French, Italian
- (3) LEDs: green (mode), yellow (warning) and red (shutdown)

Operator controls:

- (1) Raised silicone keypads, tactile feedback
- (1) Rotary switch, power on/off
- (1) Push-switch (red), engine stop

• **Power Supply:**

Operating Voltage: 8-32 VDC, reverse battery polarity and load dump protected
 Cranking Power Holdup: 0 VDC up to 50 mS(also good for brownout/blackout instances)
 Current consumption: Power on in stopped state; 117 mA at 12 VDC. Power on in standby mode; 52 mA at 12 VDC.

• **Inputs (9):**

- (5) Digital, configurable (active on High, Low, Open)
- (3) Analog, configurable (4-20 mA, 0-5V, resistive or digital ground)
- (1) Frequency, supporting:
 - Magnetic pickup (30 Hz - 10 kHz, 2.0 VAC-120 VAC) and Engine Alternator (30 Hz - 10 kHz, 4.5 VRMS - 90 VRMS)

• **Outputs (8):**

- (2) Relay, switched +DC, 10A
- (1) Relay, Form C (dry / volt-free), 10A
- (2) Low-side FET (-DC), 1A
- (2) High-side FET (+DC), 1A
- (1) Dedicated Alternator Excitation, +DC, 1A

• **Communications:**

- (1) CAN: J1939
- (1) RS485: Modbus RTU

• **Mating Connectors:**

- 21 Position, Deutsch HDP26-24-21SE,
- 31 Position, Deutsch HDP26-24-31SE

• **Physical/Environmental:**

Enclosure material: Polycarbonate
 Dimensions (WxHxD): 9.59 x 7.34 x 5.20 in. (243.48 x 186.5 x 132.23mm)
 Weight: 4 lbs (1.8 kg)
 IP rating: IP67
 Operating Temperature: -40° to +85° C (-40° to 185° F)
 Storage Temperature: -40 to +85° C (-40° to 185° F)
 Vibration: 7.86 Grms (5-2000 Hz), 3-axis random
 Shock: ±50G, 3-axis

ENOVATION CONTROLS CORPORATE HEADQUARTERS

5311 S 122ND EAST AVENUE
 TULSA, OK 74146

ENOVATION CONTROLS – SAN ANTONIO OFFICE

5757 FARINON DRIVE
 SAN ANTONIO, TX 78249

ENOVATION CONTROLS – HOUSTON OFFICE

105 RANDON DYER RD
 ROSENBERG, TX 77471

ENOVATION CONTROLS LTD. – UNITED KINGDOM

CHURCH ROAD LAVERSTOCK
 SALISBURY SP1 1QZ UK

MURPHY ECONTROLS TECHNOLOGIES (HANGZHOU) CO, LTD.

77 23RD STREET
 HANGZHOU ECONOMIC & TECHNOLOGICAL DEVELOPMENT AREA
 HANGZHOU, ZHEJIANG 310018 CHINA

U.S. SALES & SUPPORT

ECONTROLS PRODUCTS

PHONE: 210 495 9772
 FAX: 210 495 9791
 EMAIL: INFO@ENOVATIONCONTROLS.COM
 WWW.ECONTROLS.COM

MURPHY PRODUCTS

PHONE: 918 317 4100
 FAX: 918 317 4266
 EMAIL: SALES@ENOVATIONCONTROLS.COM
 WWW.FWMURPHY.COM

MURPHY CONTROL SYSTEMS & SERVICES

PHONE: 281 633 4500
 FAX: 281 633 4588
 EMAIL: CSS-SOLUTIONS@ENOVATIONCONTROLS.COM

MURPHY INDUSTRIAL PANEL DIVISION

PHONE: 918 317 4100
 FAX: 918 317 4124
 EMAIL: IPDSALES@ENOVATIONCONTROLS.COM

INTERNATIONAL SALES & SUPPORT

UNITED KINGDOM

PHONE: +44 1722 410055
 FAX: +44 1722 410088
 EMAIL: SALES@ENOVATIONCONTROLS.EU
 WWW.FWMURPHY.EU

CHINA

PHONE: +86 21 6237 5885
 FAX: +86 21 6237 5887
 EMAIL: APSALES@ENOVATIONCONTROLS.COM

LATIN AMERICA & CARIBBEAN

PHONE: 918 317 2500
 EMAIL: LASALES@ENOVATIONCONTROLS.COM

SOUTH KOREA

PHONE: +82 70 7951 4100
 EMAIL: SKOREASALES@ENOVATIONCONTROLS.COM

INDIA

PHONE: +91 91581 37633
 EMAIL: INDIASALES@ENOVATIONCONTROLS.COM



FM 28221 (Tulsa, OK - USA)
 FM 620667 (San Antonio, TX - USA)
 FM 28221 (Rosenberg, TX - USA)
 FM 29422 (UK)



FM 523851 (China) TS 589322 (China)